

Installation Instructions

PLPico

GA-E030e

CE



JEAN MÜLLER 
the name for safety

Contents

| | |
|-------------------------------------------------|-----------|
| Safety | 3 |
| Incoming inspection..... | 3 |
| Safety instructions | 3 |
| Notes on operation | 3 |
| Repairs and calibration..... | 3 |
| Front film..... | 3 |
| Front and back views of the device | 4 |
| Front elevation..... | 4 |
| Rear elevation | 5 |
| Application | 6 |
| Installation | 7 |
| Start-up | 8 |
| Electrical connection | 8 |
| Description of connections | 9 |
| Configuration | 10 |
| Using the serial interface..... | 10 |
| Using the memory card | 11 |
| Using the device dialogue | 12 |
| Using the PLConfig software..... | 12 |
| Operation | 13 |
| PLPico operation | 13 |
| Temperature control | 18 |
| Setting the date and time | 19 |
| Memory card..... | 19 |
| Pin layouts | 20 |
| RS 232 Configuration interface | 20 |
| Inputs and outputs | 20 |
| Accessories | 22 |
| Technical Data | 23 |
| Dimension drawings | 24 |

Safety

Incoming inspection

Fault-free and safe operation of this device requires technically appropriate transport conditions, storage, installation and assembly, in addition to careful operation, maintenance and repair.

Transport damage

In the event that any damage (including concealed damage) has occurred during transport, please inform us immediately on the same day.

It should be assumed that hazard-free operation is no longer possible if e.g. the device

- is visibly damaged,
- no longer works, even though the power supply is intact,

or if it has been exposed for a long period to unfavourable conditions (e.g. storage outside the permitted climate limits without readjustment to room temperature, condensation, etc.) or transport and handling stresses (e.g. a fall from a great height, even without visible exterior damage etc.).

Fatal danger of electric shock

- Only qualified electricians and personnel trained in electrical engineering may carry out the tasks described below.
- Strictly conform to your specific national regulations for installation.

Safety instructions

- Before connecting the auxiliary voltage, check the operating voltage specifications on the nameplate.
- In the case of flexible or fine-wired cables, use core end sleeves.
- Only connect screwed connector terminals when the power is off.
- When disconnecting the plug-in connector, do not pull the cables. If necessary, wedge a tool against the housing in order to lever off the connector.
- Before measuring the insulation resistance at the switchgear manufacturing plant or before on-site measurement conforming to DIN EN 60439-1 or VDE 0660 Part 500 and VDE 0100 Part 610, make sure that all module inputs are safely isolated or disconnected. These precautions are absolutely essential in order to prevent possible damage to the electronic components.

Notes on operation

This device must be installed and operated exclusively by qualified personnel in conformity with the safety provisions and specifications. In addition, when operating the device, the applicable legal and safety regulations for the particular application must be observed. "Qualified personnel" means people who are familiar with the assembly, installation, start-up and operation of the product and have the relevant qualifications for their activity, e.g.

- Training or higher education or certificate to activate, deactivate, disconnect, earth and mark circuits and devices in conformity with engineering safety standards,
- WARNING: protective transformers are not measurement transformers and cannot be used for this purpose.

Repairs and calibration

Repairs and calibration operations may only be performed at the manufacturer's works.

Front film

The front film of the display module can be cleaned with a soft cloth and standard domestic detergents. Acids and agents containing acids must not be used for cleaning.

Front and back views of the device

Front elevation

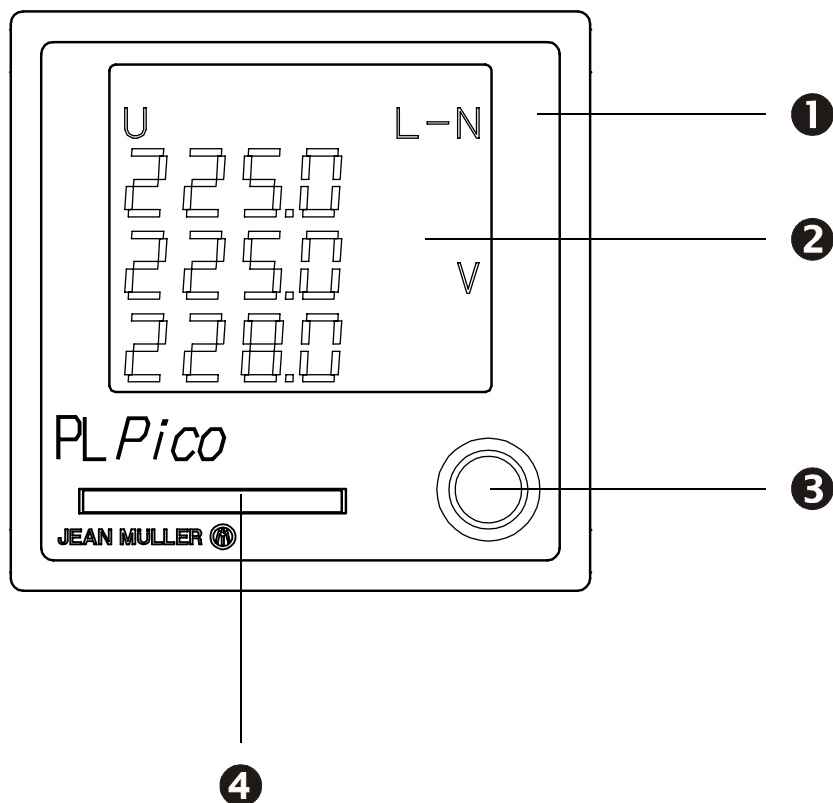

- (1) **Front screen**
Protection class IP20
- (2) **Display**
Multifunctional LCD display with 3-phase measured value display
- (3) **Control knob**
Simple, convenient operation by a single knob with turn/push mechanism
- (4) **Memory card slot**
for storing the data on a Compact Flash card (SanDisk)

Rear elevation

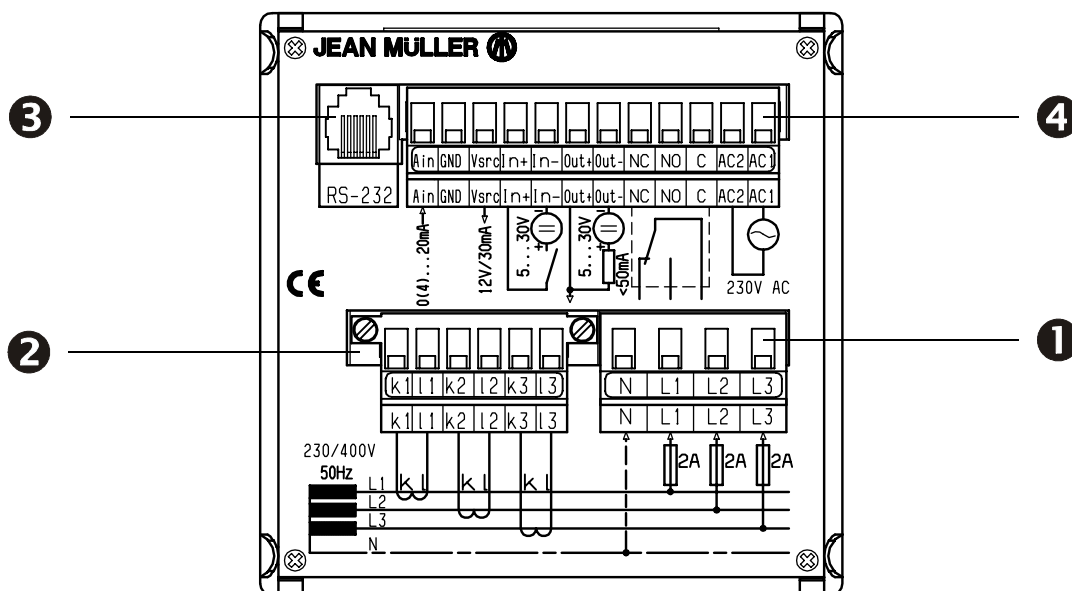

- (1) **Power supply input**
for voltage supply of L-N 3 x AC 0...500V
- (2) **Measurement input**
Current inputs, 3 x 0...6A (1A or 5A transducer, configurable)
- (3) **Configuration interface**
RS232 interface (RJ11) for configuring the device
- (4) **Various inputs/outputs and external power supply**
 - External power supply AC 230V
 - Relay output
 - Digital input/output
 - Analogue input

Application

The PLPico is a digital panel meter of the Jean Müller Powerlizer System family. It is designed for installation in control panels conforming to DIN 43700. It is characterised by its extremely compact construction and very simple and clearly arranged operating and display concept. The meter has been specially designed for efficient and low-cost monitoring and evaluation of a 3-phase outgoing/incoming line.

Minimum and maximum values and the counter values are also permanently stored in the internal EEPROM.

An additional measurement variable (e.g. temperature) can be received as standardised analogue 0/4-20mA input signal. A pulse output (active/reactive work) and a relay output are also available for limit values. The following electrical variables are determined as phases and summation values:

- Current
- Voltage (L-N)
- Voltage (L-L)
- Reactive work (procurement, delivery)
- Active work, (procurement, delivery)
- Active power
- Reactive power
- Apparent power
- Power factor

In addition to the above instantantaneous values, the measured values can be saved as maximum, minimum and average values.

The averaging time can be selected for each variable.

The PLPico is used in low voltage switchgear that requires the monitoring and evaluation of a 3-phase outgoing/incoming line. With this meter, the measured values can either be displayed directly on-site or saved on memory card for later access and analysis.

Installation

The device is intended for installation in a control panel conforming to DIN43700 with a cutout of 92mm.

It is fixed by sliding the PLPico meter into the control panel cutout until the fixing clips engage. The guide adapters, which are detachable at the sides, are used to compensate for inexact control panel cutouts. If the control panel cutout fits exactly, then these guide adapters need not be used.

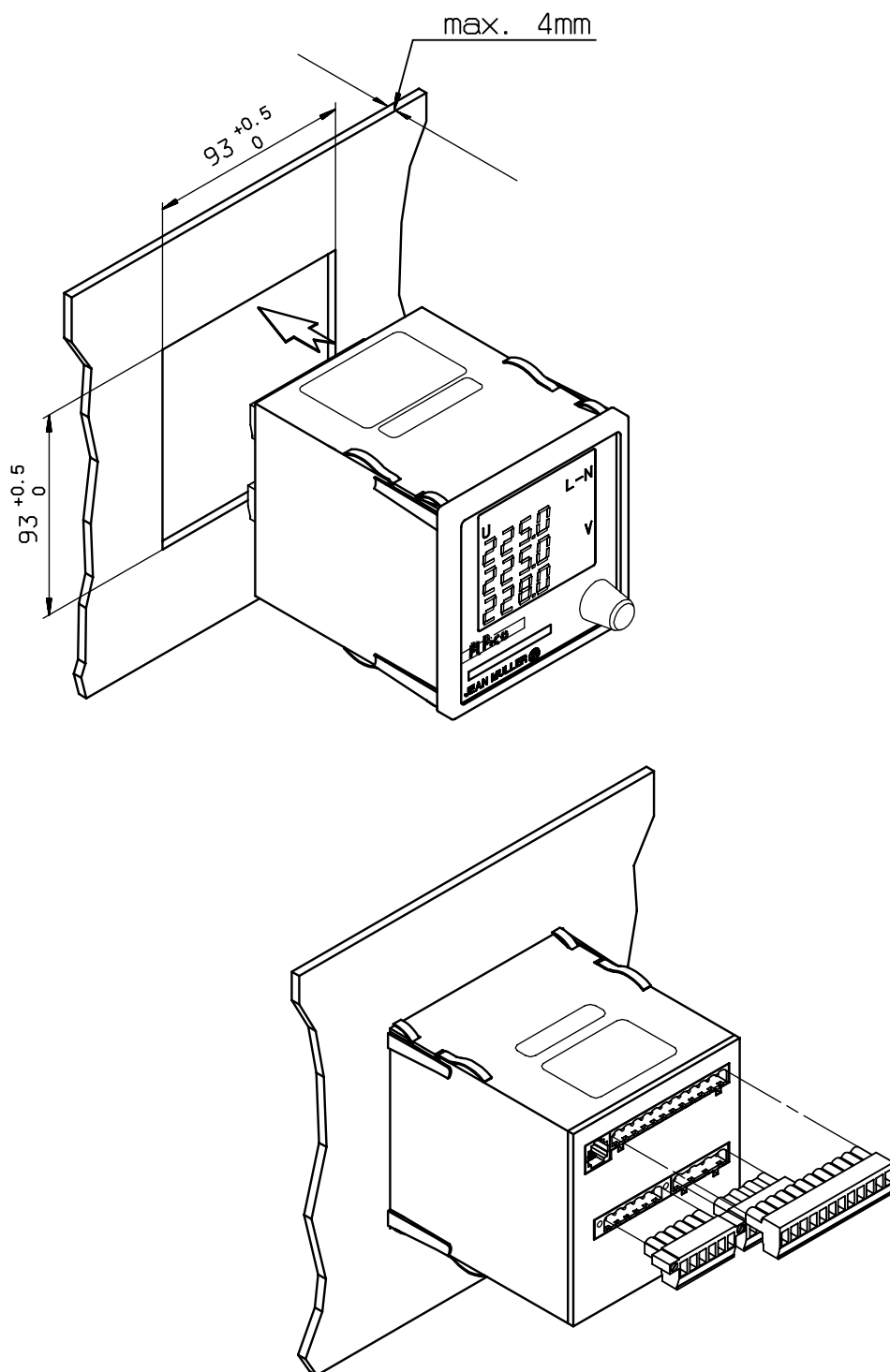

Start-up

Electrical connection

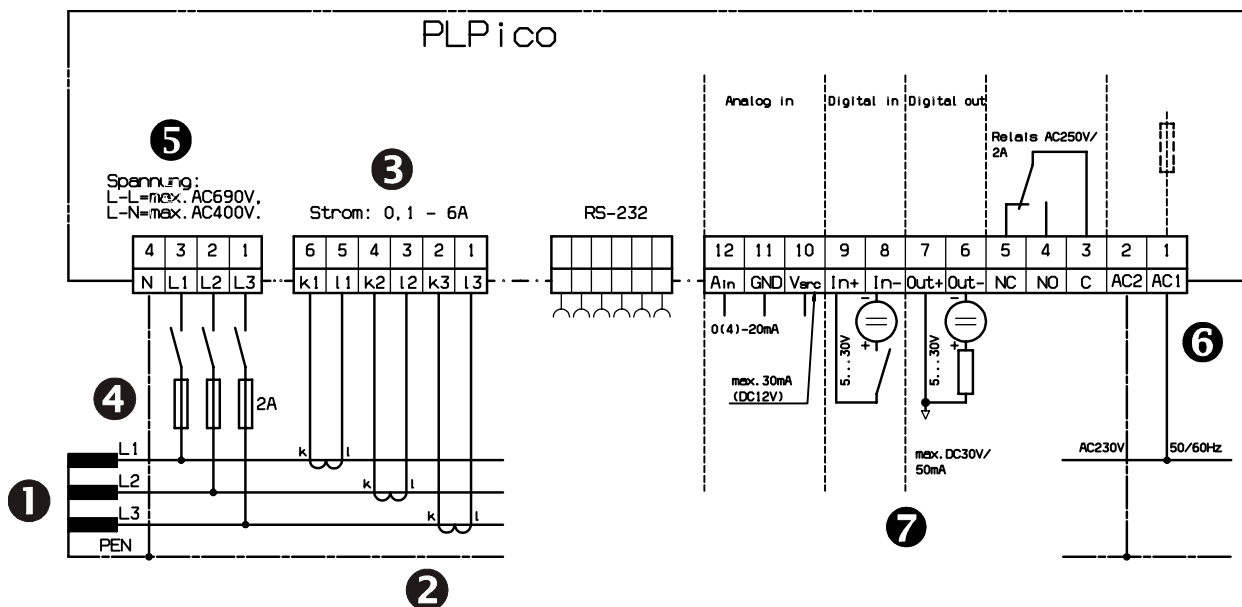

Voltage
Current
Relay AC250V...

- (1) Power supply
- (2) Transducer
- (3) Transducer connection
- (4) Upstream fuses in the voltage path
- (5) Power supply connection
- (6) External power supply
- (7) Various inputs/outputs

Description of connections

The PLPico meter is designed for taking measurements on a 3-phase sinusoidal network with a frequency of 50Hz **(1)**.

The connected power supply voltage **(5)** must be in the range from AC60 to 500V (L- N).
The voltage path must be protected with Class gL 2A fuses **(4)**.

The electrical connections must be as shown in the wiring diagram. As measurement transducers **(2)**, transformer types with 1A and 5A secondary may be used. The measurement channel connection is designed for measuring a 3-phase system with transformers in each phase. According to VDE 0414, the connection designations of the transformers conform to k=S1 and l=S2.

The external power supply **(6)** is AC 230V.

Configuration

The device should preferably be configured via the serial interface using the PLConfig configuration software.

The device can also be configured from the memory card.

A selection of the most important configuration parameters can also be adjusted directly on the device by system dialogue.

Using the serial interface

Connect the measuring instrument (RJ11 socket) to the COM interface (SUB 9 D) of the computer with a serial interface cable (see Accessories).

The PLConfig configuration software should be installed on the PC.

- Start the PLConfig program.
- Select the device you wish to configure (PLPico).
- The basic menu of the configuration program will then be displayed.

You can now “download” the current configuration of the device by selecting the “Configuration” option on the menu. The progress of downloading is displayed on the screen. When data transfer is complete, the Configuration Editor is automatically opened, and you can edit the configuraton.

(see “Configuration – PLConfig”)

When you have terminated the configuration, you can upload it into the device by selecting the “Configuration” -> “Send” menu option.

The progress of upload transmission is displayed on the screen. When data transfer is complete, the device is automatically restarted. The new configuration will now be active.

Using the memory card

The configuration file can be loaded into the device using a compact flash memory card as data storage medium. Conversely, the present device configuration can be written to the compact flash card and then edited with the PLConfig configuration software package.

From the main menu of the meter, you can access the configuration menu by selecting the “Conf” symbol. The 6th display in the configuration menu (“Card”) is used to transfer the configuration file. Select the “Card” -> “rEAd” option to load a configuration file from the memory card into the device. The filename must match the filename on the device (configuration file = PICO1251.pyd if device ID = 1251), otherwise the configuration will not be loaded. Memory card access is indicated in the display by the identifier “Crd”.

Select the “Card” -> “St15” parameter to write the present device configuration to the memory card in the form of a configuration file. The configuration filename conforms to the format – PICOxxxx.pyd (where xxxx = current device ID).

Example: device ID 1251 = Configuration file PICO1251.pyd).

The configuration file generated by this process can now be edited using the PLConfig configuration software. Remove the compact flash card from the meter and insert it in a CF card reader connected to the computer. If using a Notebook computer, please use an adapter (see Accessories), which enables you to connect the compact flash memory card directly to the PCMCIA card slot of the computer.

The PLConfig configuration software should be installed on the PC.

- Start the PLConfig program.
- Select the device you wish to configure (PLPico).
- The basic menu of the configuration program will then be displayed.
You can now load the present configuration of the device by selecting the “Open” option on the menu. Follow the instructions on the screen. In the first dialogue, please select the root directory of the memory card (e.g. movable disk E:).
The configuration file will now be displayed (e.g. PICO1251.PYD).
Select the relevant file and open it.
Once the file is loaded, the Configuration Editor is automatically opened, and you can edit the configuraton (see “Configuration – PLConfig”)
When you have terminated the configuration, you can store it on the memory card under the menu option “Configuration” -> “Save as...”.
A message will be displayed warning you that a file of this name already exists on the card. Follow the instructions on the screen.
When the configuration has been saved on the memory card, the card can be removed from the computer, inserted in the device and loaded.

Using the device dialogue

Various important configuration parameters can be adjusted directly by device dialogue. The configuration menu can be accessed from the main menu of the meter by selecting the “Conf” symbol. The identifier “Cfg” appears in the display to indicate that the device is in Configuration Mode. The 1st and 2nd displays of this sub-menu are the date and time (see Date and Time).

The 3rd display of the Configuration menu is the configuration parameter “U – U”.

- Top: primary measurement voltage (500 V; 10 kV; 20kV; 30kV) in V.
- Bottom: secondary measurement voltage (500; 100) in V.

In a low voltage network, the setting 500 – 500 V must be entered. This value is also the default. The other settings are only used when the device is used in a medium voltage network (e.g. 10 kV- 100 V).

The 4th display of the Configuration menu is the “I – I” configuration parameter.

- Top: primary transformer current (0 - 9990) in A.
- Bottom: secondary transformer current (1; 5) in A.

The 5th display of the Configuration menu is the “Au9” configuration parameter.

- Averaging time of the measured values; this value is also used as the saving interval for storing the measured data
(1; 5; 8; 10; 15; 30; 60) minutes.

The 6th display of the Configuration menu is the “Card” parameter.
(see Configuration using the memory card).

The 7th display of the Configuration menu is the “nInH” parameter.

- This parameter can be used to reset the minimum and maximum values.

The 8th and last display of the Configuration menu is the “unit” parameter.

- With this parameter, you can enter the individual device identifier (ID number) (1 – 9999).

Using the PLConfig software

The device is generally configured by means of the PLConfig configuration software, which is included with the device on delivery.

The parameters of the meter are displayed in a clearly organised tree structure on the left-hand side of the Configuration Editor screen. The essential operating parameters (compulsory parameters) are highlighted in yellow. User-specific parameters (optional parameters) are displayed in grey. Informative parameters (which can be adjusted using the device dialogue) are displayed in blue.

The parameters are subdivided into groups:

- Default settings
- Installation
- Saving to memory card
- Analogue input
- Digital input
- Operating parameters (for relay and transistor output)

On selecting a specific parameter, the relevant input field is displayed on the right-hand side of the Configuration Editor screen. The parameter can then be changed and saved with the aid of tables or by freely selectable entries. An information text on the parameter explains its function.

From the main “Configuration” menu, the configuration can be saved to the data storage medium, loaded in the device or printed out.

The language used for the entire program can be changed after start-up with the “Settings” -> “Language” (“Einstellungen” -> “Sprache”) option.

A firmware update of the measuring instruments can be obtained by selecting “Service” -> “Firmware Update”.

A Help System provides general information on how to use the program.

Operation

PLPico operation

The PLPico digital meter is easy and convenient to operate using the combined turn-and-push rotary control knob on the front panel. Simply turn the knob to display the 12 main menus.

Each main menu is the starting point for all the sub-menus. You enter the desired sub-menus by pressing the knob once. You then simply turn the knob to display all the values of this sub-menu. If you press the knob on the last value of the sub-menu, you are automatically returned to the relevant main menu. In all the main menus (except for the Configuration main menu), you can only display information, such as measured values, performance data etc. but not change it.

In the Configuration main menu, you can configure or define the parameters of the individual values.

All the main menus and their sub-menus are listed and described in detail below.

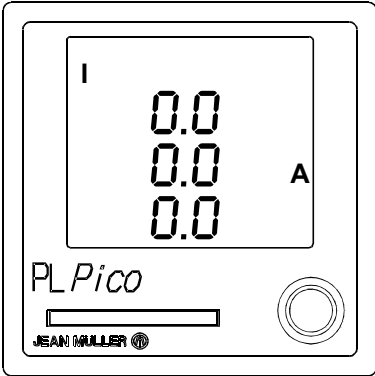
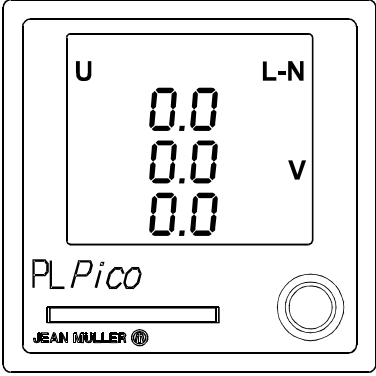
| Main menu | Sub-menu |
|-------------------------------------------------------------------------------------|--------------------------------------------------------------------------------------------------------|
| 1st display Current L1, L2, L3 Instantaneous values (effective) | 1st display Summation value of currents Instantaneous value (effective) |
|  | 2nd display Current L1, L2, L3 average values (averaged over T) |
| | 3rd display Summation value of currents Average value (averaged over T) |
| | 4th display Current L1, L2, L3 Maximum values (highest occurred average value) |
| | 5th display Summation value of currents Maximum value (highest occurred average value) |
| | 6th display Current L1, L2, L3 Minimum values (lowest occurred average value) |
| | 7th. display Summation value of currents Minimum value (lowest occurred average value) |
| | 2nd display Voltage L1, L2, L3 Instantaneous value L-N (effective) |
|  | 2nd display Voltage L1, L2, L3 Maximum values (highest occurred average value) |
| | 3rd display Voltage L1, L2, L3 Minimum values (lowest occurred average value) |

3rd display

Voltage L1, L2, L3 Instantaneous values L- L (effective)

1st display

Voltage L1, L2, L3 Maximum values (highest occurred average value)

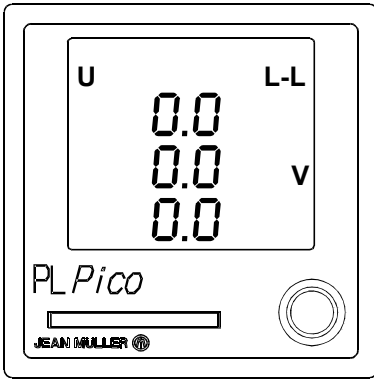

2nd display

Voltage L1, L2, L3 Minimum values (lowest occurred average value)

4th display

Power factor L1, L2, L3 Instantaneous values (effective)

1st display

Summation value for power factor Instantaneous value (effective)

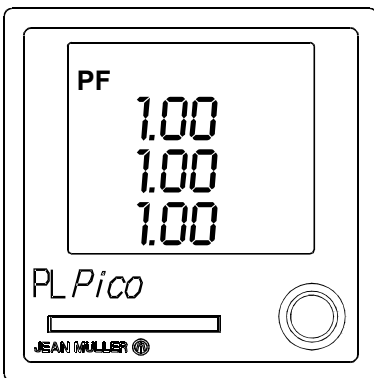

2nd display

Power factor L1, L2, L3 average values (averaged over T)

3rd display

Summation value for power factor Average value (averaged over T)

4th display

Power factor L1, L2, L3 Minimum values (lowest occurred average value)

5th display

Active power L1, L2, L3 Instantaneous values (effective)

1st display

Summation value for active power Instantaneous value (effective)

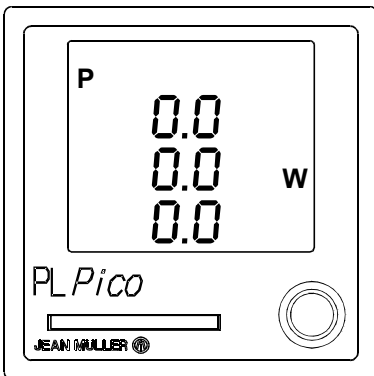

2nd display

Active power L1, L2, L3 average values (averaged over T)

3rd display

Summation value for active power Average value (averaged over T)

4th display

Active power L1, L2, L3 Maximum values (highest occurred average value)

5th display

Summation value for active power Maximum value (highest occurred average value)

6th display

Active power L1, L2, L3 Minimum values (lowest occurred average value)

7th display

Summation value for active power Minimum value (lowest occurred average value)

6th display Reactive power L1, L2, L3
Instantaneous values (effective)

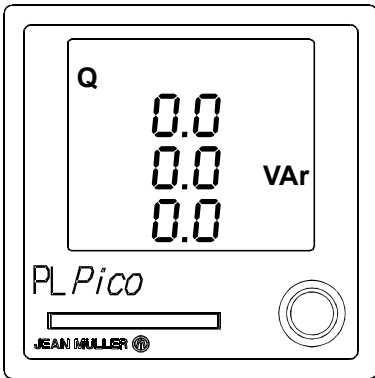

1st display Summation value for reactive
power
Instantaneous value (effective)

2nd display Reactive power L1, L2, L3 average
values (averaged over T)

3rd display Summation value for reactive
power
Average value (averaged over T)

4th display Reactive power L1, L2, L3
Maximum values (highest occurred
average value)

5th display Summation value for reactive
power
Maximum value (highest occurred
average value)

6th display Reactive power L1, L2, L3
Minimum values (lowest occurred
average value)

7th display Summation value for reactive
power
Minimum value (lowest occurred
average value)

7th display Apparent power L1, L2, L3
Instantaneous values (effective)

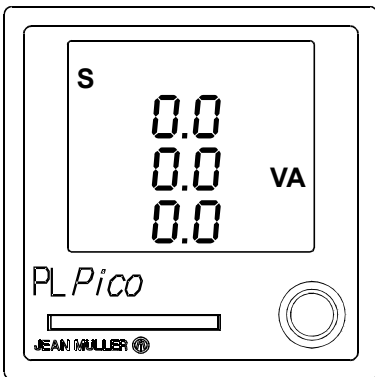

1st display Summation value for apparent
power Instantaneous value
(effective)

2nd display Apparent power L1, L2, L3
average values (averaged over T)

3rd display Summation value for apparent
power Average value (averaged
over T)

4th display Apparent power L1, L2, L3
Maximum values (highest occurred
average value)

5th display Summation value for apparent
power
Maximum values (highest occurred
average value)

6th display Apparent power L1, L2, L3
Minimum values (lowest occurred
average value)

7th display Summation value for apparent
power
Minimum value (lowest occurred
average value)

8th display

Active work, counter summation value (procurement)

1st display

Active work, counter summation value (delivery)

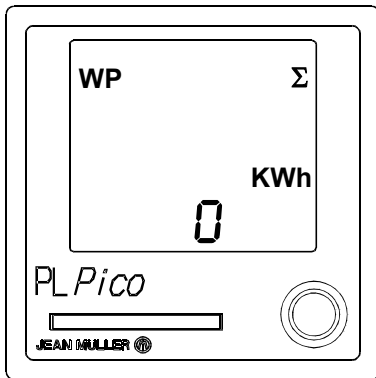

9th display

Reactive work, counter summation value (procurement)

1st display

Reactive work, counter summation value (delivery)

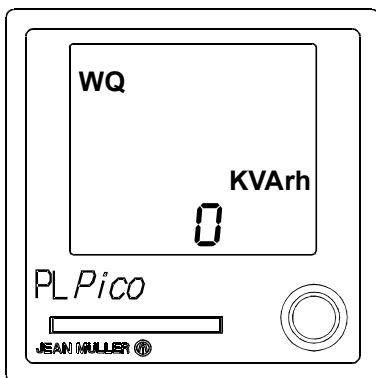

10th display

Analogue input 0-20 mA or 4-20 mA

1st display

none

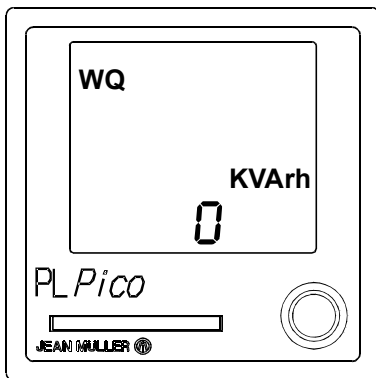

11st display Device name, Unit 1000
(selectable 1000- 9999)

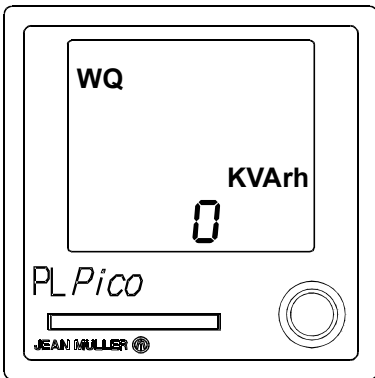

12nd display Configuration
To modify values in a sub-menu,
you must press the turn-and-press
knob again in the relevant menu.

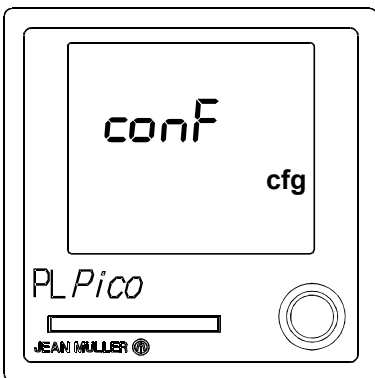

1st display Current date
2nd display Current time
3rd display Memory card
1. Card capacity
2. Net capacity
4th display Software version e.g. 1.01
5th display Serial number
e.g. 500000 (100000- 999999)

1st display Set date
2nd display Set time
3rd display Voltage range
1. Primary voltage
2. Secondary voltage
(only when using voltage
transformers, otherwise primary
and secondary 500 V)
4th display Current transformer setting
1. Primary current
(variable from 0- 9999)
2. Secondary current (1 and 5)
5th display Averaging period
(1- 5- 8- 10- 15- 30- 60)
6th display Memory card
1. Read (read)
2. Write (store)
7th display Minimum/ Maximum values
(erase)
(value of last averaging period)
8th display Name
(Device name can only be entered
on the device itself)

Temperature control

The temperature (e.g. transformer temperature) is signalled by the analogue 0/4 – 20 mA DC input. The output relay is controlled as a function of temperature by means of a limit value circuit. Two limit values control the output relay (Temperature limit value 1 “Preswitching value”, and Temperature limit value 2 “Safety limit value “). Both limit values have an activation delay and hysteresis. With these parameters, all the functions of open-loop temperature-dependent output relay control can be adjusted at will. The relay switching position is shown in the display by an indicator.

All parameter settings for this open-loop control can only be adjusted using the PLConfig configuration software.

The temperature control parameters are accessed from the Configuration menu (PLConfig) under the option “Operating parameters” -> “Relay output”

| Parameter | Unit | Value |
|---------------------------------|-----------------|----------------------------|
| Limit setting for temperature 1 | degrees Celsius | 1 – 999 |
| Limit setting for temperature 2 | degrees Celsius | 1 – 999 |
| Hysteresis for Limit 1 | degrees Celsius | 1 – 999 |
| Hysteresis for Limit 2 | degrees Celsius | 1 – 999 |
| Switching delay for Limit 1 | seconds | 1 – 9999 |
| Switching delay for Limit 1 | seconds | 1 – 9999 |
| Switching pulse duration | seconds | (0)1 – 99; 0 = statical ON |

Operation of the transformer protection circuit

The temperature control must be activated by selecting “Transformer protection” under the parameter “Default settings” -> “Relay output function”.

Temperature limit 1 (Temperature preset limit 1) must be set to a temperature that the transformer can withstand over a relatively long period of time without damage. The “Switching delay for Limit 1” takes into account this period of time. If the temperature of the transformer exceeds this limit value continuously, the output relay will switch over after expiry of the switching delay. The transformer is thereby switched off. If the temperature drops below the temperature limit value again during the switching delay, the switching function is restarted.

The hysteresis for Limit 1 is a switching hysteresis in degrees Celsius for temperature limit 1, in order to prevent an immediate restart of the transformer. The restart temperature is therefore the temperature obtained by subtracting the specified hysteresis value from temperature limit 1. When the temperature drops below the restart temperature, the transformer can be switched on again.

Given the function concerned, the hysteresis should be set to a low value.

Temperature limit 2 (temperature preset limit 2) is the safety limit temperature at which the transformer must be immediately switched off. The switching delay (Switching delay for Limit 2) should therefore be set to a suitably short time-delay to ensure immediate cut-off.

The hysteresis for Limit 2 specifies a temperature difference in degrees Celsius and represents the transformer restart temperature. This temperature is therefore the value obtained by subtracting the hysteresis value from the safety limit temperature. When the temperature drops below the restart temperature, the transformer can be switched on again.

Example: Temperatur limit value 2 = 200 degrees Celsius
 Switching delay for Limit 2 = 300 seconds
 Hysteresis for Limit 2 = 50 degrees Celsius

If the temperature at the transformer exceeds 200 degrees for 5 minutes, the output relay is activated and the transformer is cut off.

If the temperature at the transformer drops below 150 degrees Celsius, the relay is de-energised, and the transformer can be switched on again.

Setting the date and time

The date and time are set directly on the device, via the “conf” parameter in the main menu of the device. No facility is provided for setting the date and time by the PLConfig configuration software.

Setting:

- Main menu: “conf” parameter.

Press the control knob to display the 1st display of this sub-menu, i.e. the current date. The date is displayed in the sequence Day / Month / Year – from top to bottom. Press the knob again to move the cursor to the first digit of the date. The figure to be modified flashes. The desired number can be set by turning the knob clockwise or counter-clockwise. Press the knob again to confirm the displayed value. After confirmation, the cursor jumps to the next digit of the date. This digit can be adjusted in the same way as the first digit. If you do not wish to change the figures, you can confirm them by pressing the knob to go directly to the next number. After the last figure, the year number, has been confirmed, the complete date is stored in memory. The indicator “Cfg” flashes briefly in the display.

Press the control knob again to access the 2nd display of the sub-menu, the time. Here, the sequence is Hours / Minutes / Seconds. The time is set in the same way as the date. When setting the seconds, we recommend setting the value slightly high, and then only confirming it on synchronising with a reference time.

Memory card

The memory card is a commercially available Compact Flash card made by the Sandisk company. The card can be used in all common memory sizes. More memory means longer periods of measurement data recording.

In general, the storage medium should be seen as a ring memory. When the data volume attains the total capacity of the card, the oldest data set is erased in order to store the current data set.

The total capacity and free memory on the card can be displayed on the device under the parameter “unit xxxx” in the main menu. The memory capacity information is the 3rd display of the sub-menu. Memory capacity is displayed in MB (Megabytes).

When the memory card is accessed, the identifier “Crd” appears on the display.

Measurement data storage:

The measured data is stored under the condition that the measured variable is enabled for storage and the recording interval is defined.

The average values of the measured variables are recorded: the recording interval also specifies the averaging period for the relevant variable.

Storage is enabled by selecting “Yes” for each variable under the “Store on memory card” parameter of the PLConfig configuration software.

The recording interval can be set within the range limits 1 – 60 minutes by means of the parameter “Installation” -> “Averaging period”.

The default interval is 15 minutes.

If these parameters are activated, a data set is written to the memory card at the end of each recording interval. The measurement data is stored in day files in the format “date.DAT”, e.g. 20030215.dat). The counter values are stored in day files in the format “date.WRK”, e.g. 20030215.wrk).

As a rule, the current data set is stored in standardised CSV format (comma-separated text file) and is therefore generally accessible both to our own analysis software and to other analysis systems.

The individual day files are stored together in a data directory named with the name of the measuring instrument (e.g. PICO1251).

The configuration file, with the name “devicename.PYA”, e.g. PLICO1251.pya, is written to the root directory of the memory card with the first access to the memory card. An anchor file (devicename.ANC, e.g. PLPICO1251.anc) establishes the relationship between the root directory and the data directory. In this way, the software can handle any number of measuring instruments.

Pin layouts

RS 232 Configuration interface

RJ11 Socket

| Pin No. | Signal | Description |
|---------|--------|-----------------|
| 1 | TXD | Transmit Data |
| 2 | RXD | Receive Data |
| 3 | RTS | Request To Send |
| 4 | CTS | Clear To Send |
| 5 | frei | Not used |
| 6 | GND | Signal Ground |

Inputs and outputs

| Pin No. | Signal | Description |
|---------|--------|---------------------------------------|
| L1 | | External power supply AC 230V 50/60Hz |
| N | | External power supply AC 230V 50/60Hz |
| 1 | REL_C | Relay change-over contact |
| 2 | REL_NO | Relay change-over contact |
| 3 | REL_NC | Relay change-over contact |
| 4 | OUT_M | Digital output |
| 5 | OUT_P | Digital output |
| 6 | DIN | Digital input |
| 7 | GND | Digital input |
| 8 | V_OUT | Analogue input |
| 9 | A_IN | Analogue input |
| 10 | GND | Analogue input |

Pin No. 1-3 (REL_C - REL_NC)

Relay output:

Technical Data: Max. Voltage AC250 V
Max. Switching current 2A

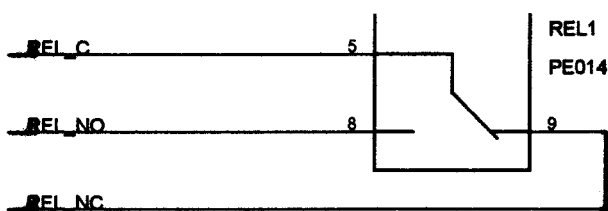

Pin No. 4-5 (OUT_M - OUT_P)

Digital output: Currently no options stored
Available for future options, e.g. S0 puls (KWh)

Technical Data: Max. Voltage DC30 V
Max. Current 50mA

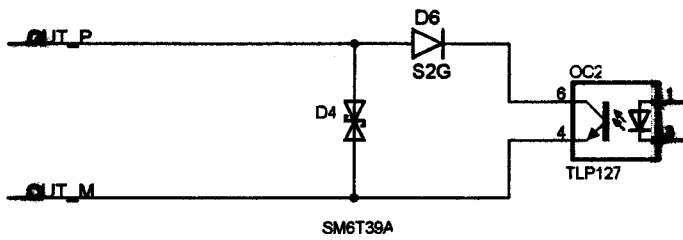

Pin No. 6-7 (DIN - GND)

Digital input: Currently no options stored

Safety warning: Do not connect any voltage-conducting contacts.
Please observe ESD Guidelines regarding short line lengths.

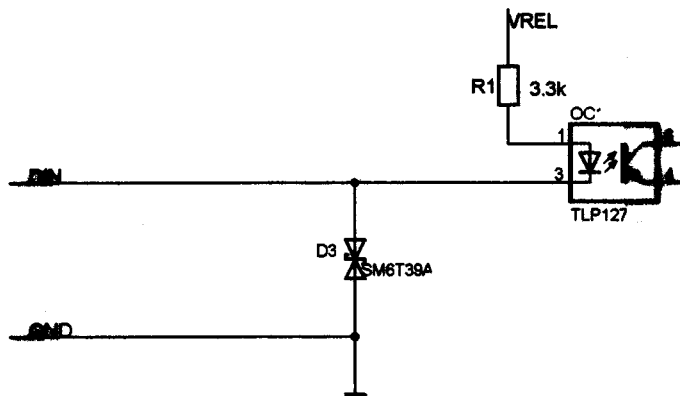

Pin No. 8-10 (V_OUT - GND)

Analogue input:

Passive mode: In this mode, the following electrical values must not be exceeded:

Pin No. 8-9

Technical Data: Max. Voltage 10V
Max. Current 35mA
Max. Load 500 Ohm

Active mode: In this mode, no voltage-conducting contacts may be connected.

Pin No. 9-10

Technical Data: 0(4) - 20mA

Accessories

| | Designation | Connector | Type | Part No. |
|-----------------------------------------------------------------------------------|-------------|-----------|---------------------------------------|----------|
|  | Memory card | — | Compact Flash Type SanDisk 32MB | E8030007 |

Description: the interchangeable PC memory card is used as a mass storage medium for the measurement data.

| | Designation | Connector | Type | Part No. |
|-----------------------------------------------------------------------------------|-------------|-----------|--------------------------------------|----------|
|  | Adapter | — | for Compact Flash memory cards | E8030008 |

Description: adapter for Compact Flash cards, fits PC Card Type II Slot.

| | Designation | Connector | Type | Part No. |
|-------------------------------------------------------------------------------------|-----------------|-------------------------|-----------------|----------|
|  | Interface cable | D-SUB-9 Buchse RJ 11 | Interface cable | E8000017 |

Description: approx. 3m
RS 232 interface: RJ11 for device configuration

| | Designation | Connector | Type | Part No. |
|--|-----------------|-----------|--------------------------|----------|
| | PLSoft Software | — | JeanLog (EVU-Version) | E7010003 |

Description: the long-term values are graphically displayed and processed. Cost centres can be easily processed and allocated. Maximum characteristics and load curves for voltage, current and electric power can be called up for different time intervals (day, week, month and year displays).

Technical Data

Measurement data acquisition systems (conforming to IEC/EN 60497-1,-3, VDE0106, EN60747-1, Tab.23)

| | | | | |
|----------------------------|----------------------------------------|----|----|-----------------------|
| Electrical characteristics | Nominal voltage | Ue | V | L-N AC 3 x 0 ... 500V |
| | Voltage range | Un | V | 0.8 to 1.1 |
| | Power consumption | Pv | VA | 3 |
| | Calibrated frequency | | Hz | 50 / 60 |
| | External power supply | U | V | AC 230 |
| | Current transformer, secondary current | I | A | 1 or 5 |

| | | | | | |
|--------|----------|--------------|---|-----|-----|
| Inputs | Digital | | | yes | |
| | Analogue | 0/4...20mA | | yes | |
| | active | | | yes | |
| | passive | Max. Voltage | U | V | 10 |
| | | Max. Current | I | mA | 35 |
| | | Max. Load | R | Ohm | 500 |

| | | | | | |
|---------|--------------|------------------------|---|---|-----------------------|
| Outputs | Relay output | Max. Voltage | U | V | AC 250 |
| | | Max. Switching current | I | A | 2 |
| | | Relay contact | | | 1 change-over contact |
| | Digital | | | | yes |

| | | | | | |
|--------------|---------------------------------------|---------------------|----|------------|------------------------|
| General Data | Temperature range | | C° | -10 to +55 | |
| | Type of use | | | any | |
| | Display | Multifunctional | | | LCD with 3-phase disp. |
| | Meas. method | TRMS meas. interval | | ms | 500 |
| | | Resolution | | bits | 12 |
| | Accuracy class, measuring instruments | | | | 1 |
| | Protection class | | | | IP 20 |
| | Installation | DIN 43700 Panel | | mm | 92 x 92 |
| | Dimensions | W x H x D | | mm | 96 x 96 x 100 |
| | Weight | Max. | | kg | 0.8 |

Dimension drawings

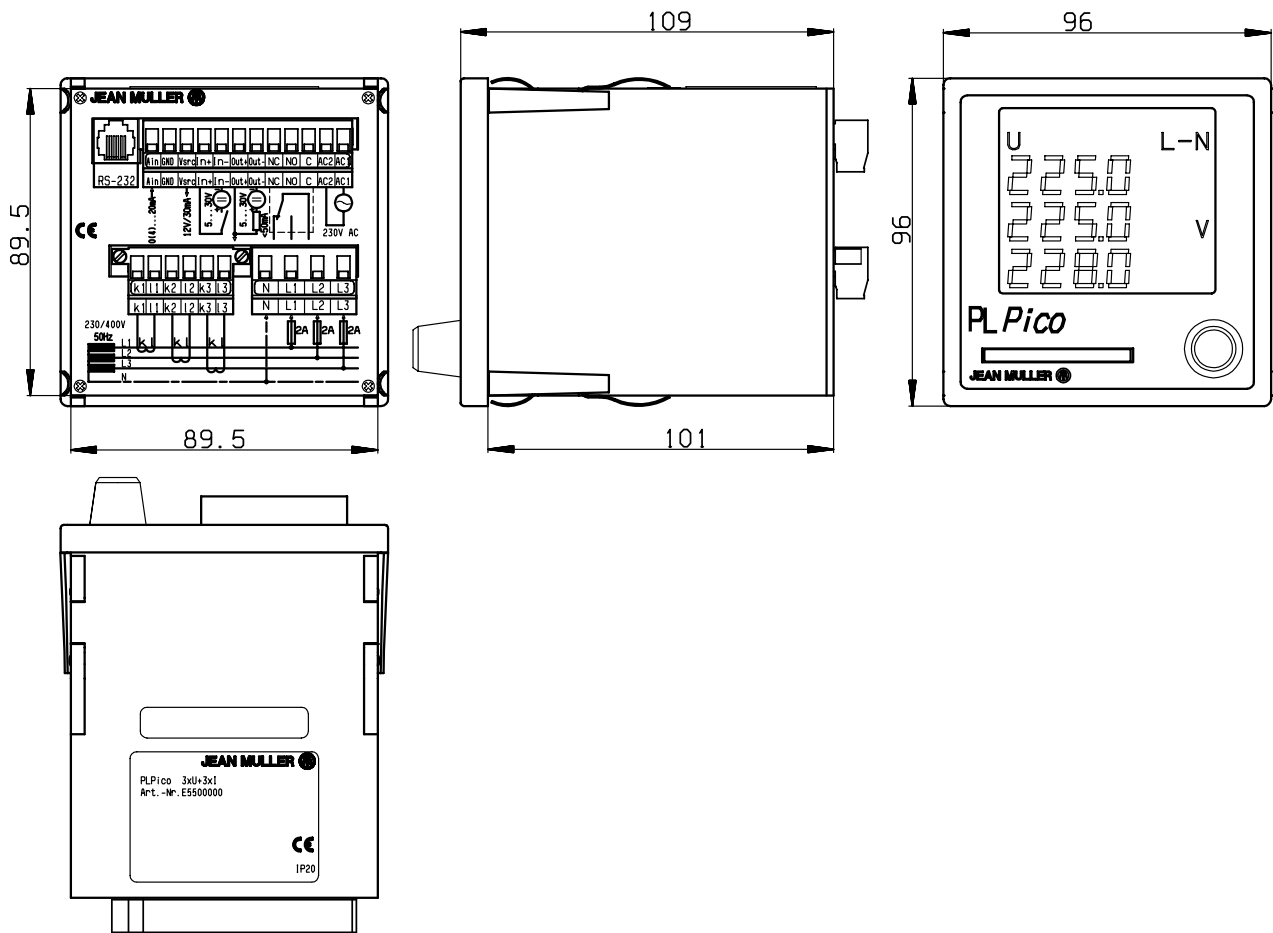

Installation Instructions GA-E030e/1455101 Edition 08/03

Subject to technical alterations

Jean Müller GmbH
 Elektrotechnische Fabrik
 H.J.-Müller-Straße 7
 D-65343 Eltville am Rhein

Phone: ++49-61 23/604 -0
 Fax: ++49-61 23/604-730
 http: www.jeanmueller.de
 E-Mail: sales@jeanmueller.de

JEAN MÜLLER 
 the name for safety