

Gebrauchsanleitung Installation Instructions

GA-L017

14589g

CE NH-Sicherungsleiste Gr. 00 für 100mm Sammelschienensysteme dreipolig schaltbar
LV HRC strip type fuse-switch-disconnector Size 00 for 100mm busbar system 3-pole switchable

Warnung:		WARNING:
	Gefährliche elektrische Spannung! Kann zu elektrischem Schlag und Verbrennungen führen. Vor Beginn der Arbeiten Anlage und Gerät spannungsfrei schalten.	Hazardous voltage can cause electrical shock and burns. Disconnect power before proceeding with any work on this equipment.

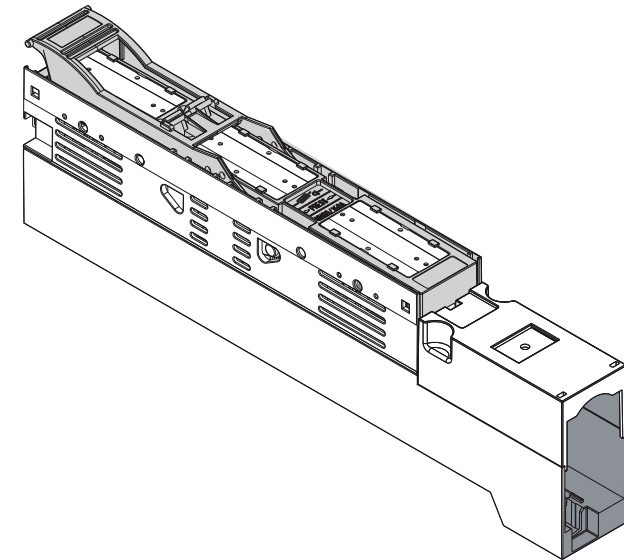

Nur Sicherungseinsätze mit versilberten Messern bzw. mit versilberten Trennlaschen verwenden!
 Use fuse-links with silver-plated terminal blades or silver-plated disconnecting links only!



① Demontage des Leistendeckels 3polig schaltbar
Removing the strip cover of the switch-fuse unit 3-pole switchable

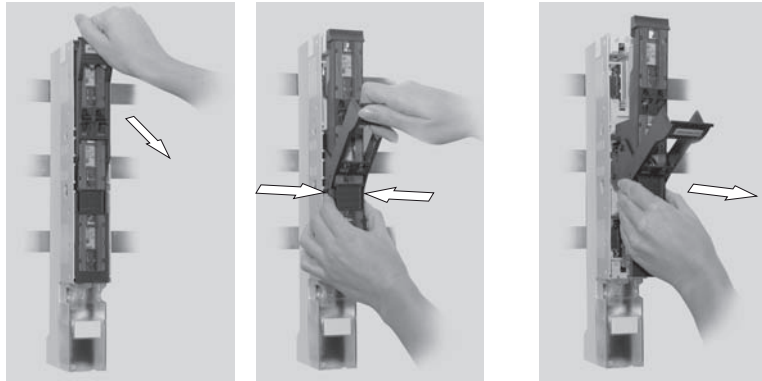

② Ein- und Ausschalten: schnell schalten
On/Off: move lever quickly!

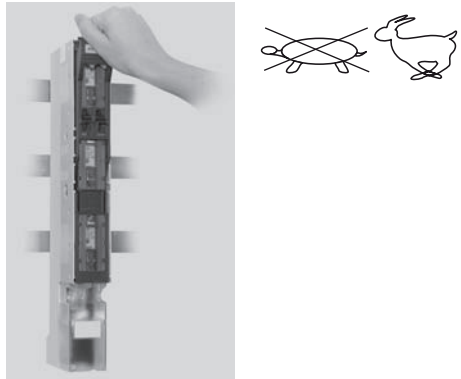

③ Anschlussraumabdeckung entfernen
Remove connection-room cover

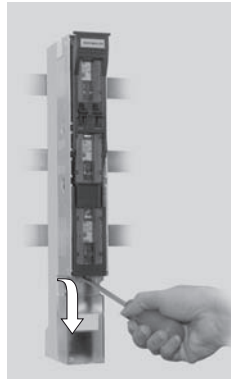

④ Sicherung entnehmen
Remove fuse link

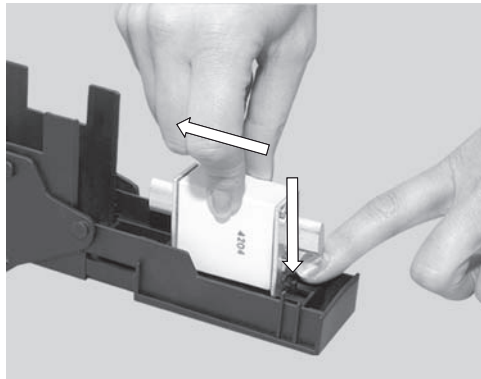

⑤ Schaltstellungsanzeige EV-SL00/100
Position indicator EV-SL00/100

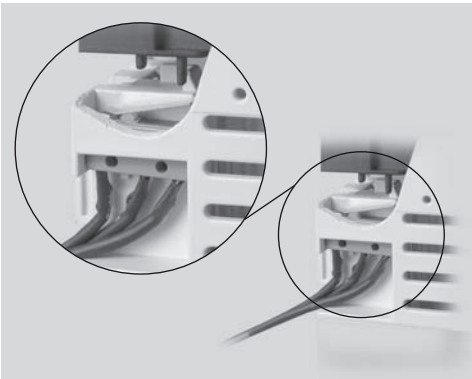

⑥ Anschluss unten
Connection, bottom

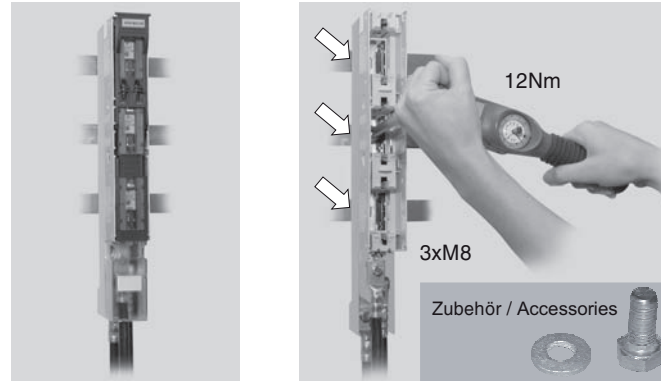



⑦ Anschluss oben
Connection, top

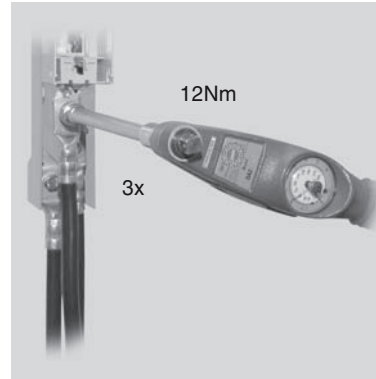

⑧ Anzugsdrehmoment / Klemmbereich
Torques / Clamping range



	F=12Nm		F70=2,6Nm Al/Cu 1,5-70mm ²
	P00=2,6Nm Al/Cu 10-70mm ²		KU00=10Nm Al/Cu 10-70mm ² Al/Cu 10-95mm ² mit Zugentlastung/ with strain relief
	S00=2,6Nm Al/Cu 1,5-70mm ²		KM00=10Nm 10-50mm ² rm/re 35-70mm ² sm 50-95mm ² se

⑨ Parkstellung
Parking position



⑩ SK-Klemme
Busbar terminal

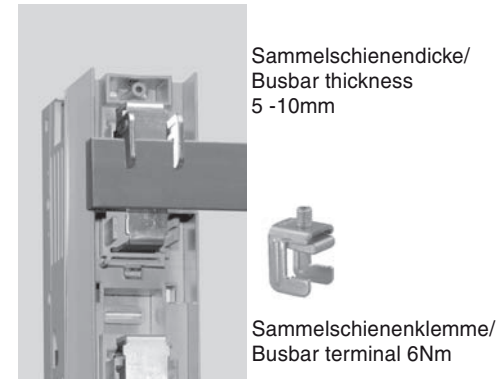

安装手册

RC

低压高分断条形熔断器隔离开关00号
安装于100mm母排系统
三极操作



警告:

系统带电操作会导致电击和烧伤
本设备安装维护前请切断电源



开关内只能使用触刀镀银的熔断器或隔离刀片

- ① 移除开关上体（三极操作开关）
- ② 快分快合
- ③ 移除端子护罩
- ④ 安装熔断器
- ⑤ 开关位置微动开关 EV-SL00/100
- ⑥ 下出线
- ⑦ 上出线
- ⑧ 锁紧扭矩 / 接线端子
- ⑨ 电流互感器安装
- ⑩ 母排挂接件 / 母排厚度 5 -10mm / 端子锁紧扭矩 6Nm
- ⑪ 尺寸

规格如有更改，恕不另行通知

版本 09/07