

# Gebrauchsanleitung Installation Instructions

# GA-G010

1453601a



**Geräteadapter  
Baugröße 160A/250A  
Device adapters 160A/250A**

**Vor Beginn der Arbeiten Gerät spannungsfrei schalten. Inbetriebsetzung und Wartung nur durch Fachpersonal. To prevent electrical shock disconnect from power source before installing or servicing. Work and maintenance by skilled staff only.**

①

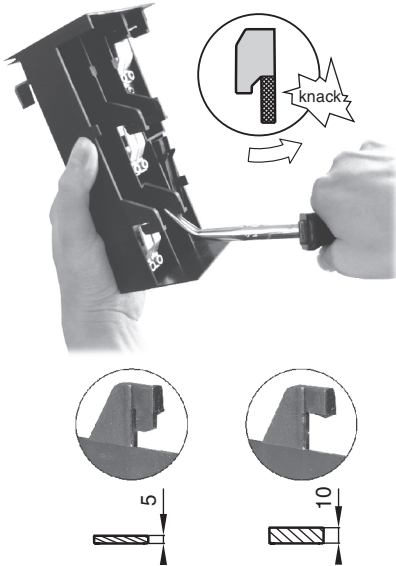

②

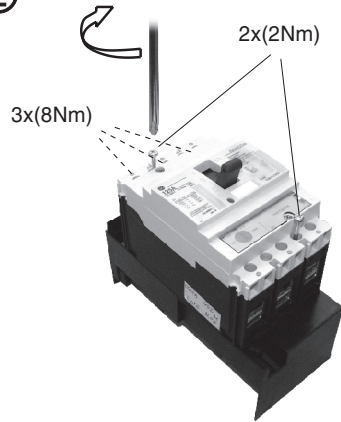

③

Montage / Assembly

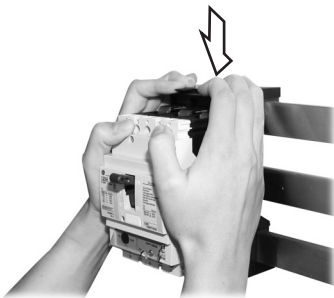

④

Demontage / Disassembly

